

# Capacitor

*This article is about the electronic component. For the physical phenomenon, see [capacitance](#). For an overview of various kinds of capacitors, see [types of capacitor](#).*

## Capacitor



Modern capacitors, by a cm rule.

**Type** [Passive](#)

**Invented** [Ewald Georg von Kleist](#) (October 1745)

### Electronic symbol



A **capacitor** or **condenser** is a [passive electronic component](#) consisting of a pair of [conductors](#) separated by a [dielectric](#). When a [voltage potential difference](#) exists between the conductors, an [electric field](#) is present in the dielectric. This field stores [energy](#) and produces a mechanical force between the plates. The effect is greatest between wide, flat, parallel, narrowly separated conductors.

An ideal capacitor is characterized by a single constant value, [capacitance](#), which is measured in [farads](#). This is the ratio of the [electric charge](#) on each conductor to the potential difference between them. In practice, the dielectric between the plates passes a small amount of [leakage current](#). The conductors and leads introduce an [equivalent series resistance](#) and the dielectric has an electric field strength limit resulting in a [breakdown voltage](#).

The properties of capacitors in a circuit may determine the resonant frequency and [quality factor](#) of a [resonant circuit](#), power dissipation and operating frequency in a [digital logic](#) circuit, energy capacity in a high-power system, and many other important system characteristics.

# Contents

[hide]

- [1 History](#)
- [2 Theory of operation](#)
  - [2.1 Energy storage](#)
  - [2.2 Current-voltage relation](#)
  - [2.3 DC circuits](#)
  - [2.4 AC circuits](#)
  - [2.5 Parallel plate model](#)
  - [2.6 Networks](#)
- [3 Non-ideal behaviour](#)
  - [3.1 Breakdown voltage](#)
  - [3.2 Equivalent circuit](#)
  - [3.3 Ripple current](#)
  - [3.4 Instability of capacitance](#)
- [4 Capacitor types](#)
  - [4.1 Dielectric materials](#)
  - [4.2 Structure](#)
- [5 Applications](#)
  - [5.1 System Energy Storage](#)
  - [5.2 Pulsed power and weapons](#)
  - [5.3 Power conditioning](#)
    - [5.3.1 Power factor correction](#)
  - [5.4 Supression and coupling](#)
    - [5.4.1 Signal coupling](#)
    - [5.4.2 Decoupling](#)
    - [5.4.3 Noise filters and snubbers](#)
  - [5.5 Motor starters](#)
  - [5.6 Signal processing](#)
    - [5.6.1 Tuned circuits](#)
  - [5.7 Sensing](#)
- [6 Hazards and safety](#)
- [7 Notes](#)
- [8 References](#)
- [9 External links](#)
- [10 See also](#)



 Battery of four [Leyden jars](#) in Museum Boerhave, [Leiden](#).

In October 1745, [Ewald Georg von Kleist](#) of [Pomerania](#) in Germany found that charge could be stored by connecting a generator by a wire to a volume of water in a hand-held glass jar.<sup>[1]</sup> Von Kleist's hand and the water acted as [conductors](#) and the jar as a [dielectric](#). Von Kleist found that after removing the generator, touching the wire resulted in a painful spark. In a letter describing the experiment, he said "I would not take a second shock for the kingdom of France."<sup>[2]</sup> The following year, the Dutch physicist [Pieter van Musschenbroek](#) invented a similar capacitor, which was named the [Leyden jar](#), after the [University of Leyden](#) where he worked.<sup>[3]</sup> [Daniel Gralath](#) was the first to combine several jars in parallel into a "battery" to increase the charge storage capacity.<sup>[citation needed]</sup>

[Benjamin Franklin](#) investigated the Leyden jar, and proved that the charge was stored on the glass, not in the water as others had assumed.<sup>[citation needed]</sup> Leyden jars began to be made by coating the inside and outside of jars with metal foil, leaving a space at the mouth to prevent arcing between the foils.<sup>[citation needed]</sup> The earliest unit of capacitance was the 'jar', equivalent to about 1 [nanofarad](#).<sup>[citation needed]</sup>

Leyden jar or flat glass plate construction was used exclusively up until about 1900, when the invention of [wireless \(radio\)](#) created a demand for standard capacitors, and the steady move to higher [frequencies](#) required capacitors with lower [inductance](#).<sup>[citation needed]</sup> A more compact construction began to be used of a flexible dielectric sheet such as oiled paper sandwiched between sheets of metal foil, rolled or folded into a small package.<sup>[citation needed]</sup>

Early capacitors were also known as *condensers*, a term that is still occasionally used today. It was coined by [Alessandro Volta](#) in 1782 (derived from the Italian *condensatore*), with reference to the device's ability to store a higher density of electric charge than a normal isolated conductor.<sup>[citation needed]</sup> Most non-English European languages still use a word derived from "condensatore".<sup>[citation needed]</sup>

## Theory of operation

Main article: [Capacitance](#)

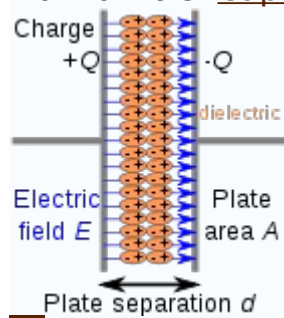

Charge separation in a parallel-plate capacitor causes an internal electric field. A dielectric (orange) reduces the field and increases the capacitance.



A simple demonstration of a parallel-plate capacitor

A capacitor consists of two [conductors](#) separated by a non-conductive region.[4] The non-conductive substance is called the [dielectric](#) medium, although this may also mean a [vacuum](#) or a [semiconductor depletion region](#) chemically identical to the conductors. A capacitor is assumed to be self-contained and isolated, with no net [electric charge](#) and no influence from an external electric field. The conductors thus contain equal and opposite charges on their facing surfaces,[5] and the dielectric contains an electric field. The capacitor is a reasonably general model for electric fields within electric circuits.

An ideal capacitor is wholly characterized by a constant [capacitance](#)  $C$ , defined as the ratio of charge  $\pm Q$  on each conductor to the [voltage](#)  $V$  between them:[4]

$$C = \frac{Q}{V}$$

Sometimes charge buildup affects the mechanics of the capacitor, causing the capacitance to vary. In this case, capacitance is defined in terms of incremental changes:

$$C = \frac{dq}{dv}$$

In [SI](#) units, a capacitance of one [farad](#) means that one [coulomb](#) of charge on each

conductor causes a voltage of one volt across the device.[6]

## Energy storage

Work must be done by an external influence to move charge between the conductors in a capacitor. When the external influence is removed, the charge separation persists and energy is stored in the electric field. If charge is later allowed to return to its equilibrium position, the energy is released. The work done in establishing the electric field, and hence the amount of energy stored, is given by:[7]

$$W = \int_0^Q V dQ' = \int_0^Q \frac{Q'}{C} dQ' = \frac{1}{2} \frac{Q^2}{C} = \frac{1}{2} CV^2 = \frac{1}{2} VQ.$$

## Current-voltage relation

The current  $i(t)$  through a component in an electric circuit is defined as the rate of change of the charge  $q(t)$  that has passed through it. Physical charges cannot pass through the dielectric layer of a capacitor, but rather build up in equal and opposite quantities on the electrodes: as each electron accumulates on the negative plate, one leaves the positive plate. Thus the accumulated charge on the electrodes is equal to the integral of the current, as well as being proportional to the voltage (as discussed above). As with any antiderivative, a constant of integration is added to represent the initial voltage  $v(t_0)$ . This is the integral form of the capacitor equation,[8]

$$v(t) = \frac{q(t)}{C} = \frac{1}{C} \int_{t_0}^t i(\tau) d\tau + v(t_0)$$

Taking the derivative of this, and multiplying by  $C$ , yields the derivative form,[9]

$$i(t) = \frac{dq(t)}{dt} = C \frac{dv(t)}{dt}$$

The dual of the capacitor is the inductor, which stores energy in the magnetic field rather than the electric field. Its current-voltage relation is obtained by exchanging current and voltage in the capacitor equations and replacing  $C$  with the inductance  $L$ .

## DC circuits

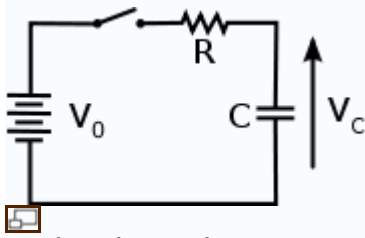

A simple resistor-capacitor circuit demonstrates charging of a capacitor.

A series circuit containing only a resistor, a capacitor, a switch and a constant DC source of voltage  $V_0$  is known as a *charging circuit*.<sup>[10]</sup> If the capacitor is initially uncharged while the switch is open, and the switch is closed at  $t = 0$ , it follows from Kirchhoff's voltage law that

$$V_0 = v_{\text{resistor}}(t) + v_{\text{capacitor}}(t) = i(t)R + \frac{1}{C} \int_0^t i(\tau) d\tau.$$

Taking the derivative and multiplying by  $C$ , gives a first-order differential equation,

$$RC \frac{di(t)}{dt} + i(t) = 0.$$

At  $t = 0$ , the voltage across the capacitor is zero and the voltage across the resistor is  $V_0$ . The initial current is then  $i(0) = V_0/R$ . With this assumption, the differential equation yields

$$i(t) = \frac{V_0}{R} e^{-t/\tau_0}$$
$$v(t) = V_0 \left( 1 - e^{-t/\tau_0} \right),$$

where  $\tau_0 = RC$  is the time constant of the system.

As the capacitor reaches equilibrium with the source voltage, the voltage across the resistor and the current through the entire circuit decay exponentially. The case of *discharging* a charged capacitor likewise demonstrates exponential decay, but with the initial capacitor voltage replacing  $V_0$  and the final voltage being zero.

## AC circuits

See also: [reactance \(electronics\)](#) and [electrical impedance#Deriving the device specific impedances](#)

[Impedance](#), the vector sum of [reactance](#) and [resistance](#), describes the phase difference and the ratio of amplitudes between sinusoidally varying voltage and sinusoidally varying current at a given frequency. [Fourier analysis](#) allows any signal to be constructed from a [spectrum](#) of frequencies, whence the circuit's reaction to the various frequencies may be found. The reactance and impedance of a capacitor are respectively

$$X = -\frac{1}{\omega C} = -\frac{1}{2\pi f C}$$
$$Z = \frac{1}{j\omega C} = -\frac{j}{\omega C} = -\frac{j}{2\pi f C}$$

where  $j$  is the [imaginary unit](#) and  $\omega$  is the [angular velocity](#) of the sinusoidal signal. The  $-j$  phase indicates that the AC voltage  $V = Z I$  lags the AC current by  $90^\circ$ : the positive current phase corresponds to increasing voltage as the capacitor charges, zero current corresponds to instantaneous constant voltage, etc.

Note that impedance decreases with increasing capacitance and increasing frequency. This implies that a higher-frequency signal or a larger capacitor results in a lower voltage amplitude per current amplitude—an AC "short circuit" or [AC coupling](#). Conversely, for very low frequencies, the reactance will be high, so that a capacitor is nearly an open circuit in AC analysis—those frequencies have been "filtered out".

Capacitors are different from resistors and inductors in that the impedance is *inversely* proportional to the defining characteristic, i.e. capacitance.

## Parallel plate model

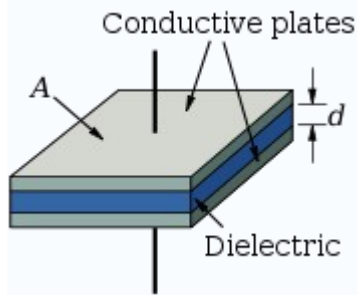

Dielectric is placed between two conducting plates, each of area  $A$  and with a separation of  $d$ .

The simplest capacitor consists of two parallel conductive plates separated by a dielectric with permittivity  $\epsilon$ . The model may also be used to make qualitative predictions for other device geometries. The plates are considered to extend uniformly over an area  $A$  and a charge density  $\pm\rho = \pm Q/A$  exists on their surface. Assuming that the width of the plates is much greater than their separation  $d$ , the electric field near the centre of the device will be uniform with the magnitude  $E = \rho/\epsilon$ . The voltage is defined as the line integral of the electric field between the plates

$$V = \int_0^d E dz = \int_0^d \frac{\rho}{\epsilon} dz = \frac{\rho d}{\epsilon} = \frac{Qd}{\epsilon A}.$$

Solving this for  $C = Q/V$  reveals that capacitance increases with area and decreases with separation

$$C = \frac{\epsilon A}{d}.$$

The capacitance is therefore greatest in devices made from materials with a high permittivity.

## Networks

See also: [Series and parallel circuits](#)

### For capacitors in parallel

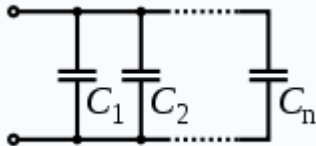

Several capacitors in parallel.

Capacitors in a parallel configuration each have the same applied voltage. Their capacitances add up. Charge is apportioned among them by size. Using the schematic diagram to visualize parallel plates, it is apparent that each capacitor contributes to the total surface area.

$$C_{eq} = C_1 + C_2 + \dots + C_n$$

### For capacitors in series

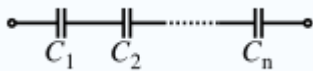

Several capacitors in series.

Connected in series, the schematic diagram reveals that the separation distance, not the plate area, adds up. The capacitors each store instantaneous charge build-up equal to that of every other capacitor in the series. The total voltage difference from end to end is apportioned to each capacitor according to the inverse of its capacitance. The entire series acts as a capacitor *smaller* than any of its components.

$$\frac{1}{C_{eq}} = \frac{1}{C_1} + \frac{1}{C_2} + \dots + \frac{1}{C_n}$$

Capacitors are combined in series to achieve a higher working voltage, for example for smoothing a high voltage power supply. The voltage ratings, which are based on plate separation, add up. In such an application, several series connections may in turn be connected in parallel, forming a matrix. The goal is to maximize the energy storage utility of each capacitor without overloading it.

Series connection is also used to adapt [electrolytic capacitors](#) for AC use.

## Non-ideal behaviour

Capacitors deviate from the ideal capacitor equation in a number of ways. Some of these, such as leakage current and parasitic effects are linear, or can be assumed to be linear, and can be dealt with by adding virtual components to the [equivalent circuit](#) of the capacitor. The usual methods of [network analysis](#) can then be applied. In other cases, such as with breakdown voltage, the effect is non-linear and normal (i.e., linear) network analysis cannot be used, the effect must be dealt with separately. There is yet another group, which may be linear but invalidate the assumption in the analysis that capacitance is a constant. Such an example is temperature dependence.

### Breakdown voltage

Main article: [Breakdown voltage](#)

Above a particular electric field, known as the dielectric strength  $E_{ds}$ , the dielectric in a capacitor becomes conductive. The voltage at which this occurs is called the [breakdown voltage](#) of the device, and is given by the product of the dielectric strength and the separation between the conductors,[\[11\]](#)

$$V_{bd} = E_{ds}d$$

The maximum energy that can be stored safely in a capacitor is limited by the breakdown voltage. Due to the scaling of capacitance and breakdown voltage with dielectric thickness, all capacitors made with a particular dielectric have approximately equal maximum [energy density](#), to the extent that the dielectric dominates their volume.[\[12\]](#)

For air dielectric capacitors the breakdown field strength is of the order  $10^7$  V/m and will be much less when other materials are used for the dielectric. The absolute breakdown voltage of most capacitors is nowhere near such a high number because of the very small distance between the plates. Typical ratings for capacitors used for general electronics applications range from a few volts to 100V or so. For high voltage applications physically much larger capacitors have to be used. In this field, there are a number of factors that can dramatically reduce the breakdown voltage below that to be expected by considering the breakdown field strength of the dielectric alone. For one thing, the geometry of the capacitor conductive parts (plates and connecting wires) is important. In particular, sharp edges or points hugely increase the electric field strength at that point and can lead to a local breakdown. Once this starts to happen, the breakdown will quickly "track" through the dielectric till it reaches the opposite plate and cause a short circuit.[\[13\]](#)

The usual breakdown route is that the field strength becomes large enough to pull electrons in the dielectric from their atoms thus causing conduction. Other scenarios are possible, such as impurities in the dielectric, and, if the dielectric is of a crystalline nature, imperfections in the crystal structure can result in an [avalanche breakdown](#) as

seen in semi-conductor devices. Breakdown voltage is also affected by pressure, humidity and temperature.[14]

### Equivalent circuit

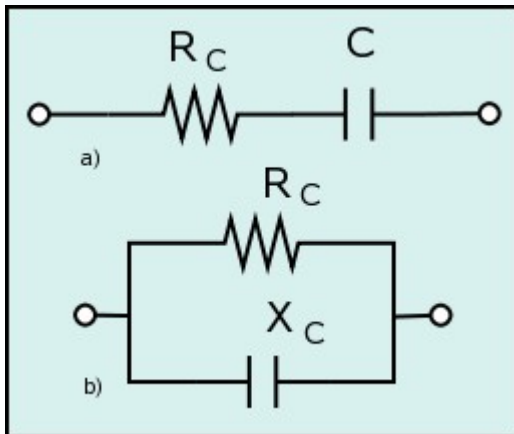

Two equivalent circuits of a real capacitor

An ideal capacitor only stores and releases electrical energy, without dissipating any. In reality, all capacitors have imperfections within the capacitor's material that create resistance. This is specified as the equivalent series resistance or ESR of a component. This adds a real component to the impedance:

$$R_C = Z + R_{\text{ESR}} = \frac{1}{j\omega C} + R_{\text{ESR}}$$

As frequency approaches infinity, the capacitive impedance (or reactance) approaches zero and the ESR becomes significant. As the reactance becomes negligible, power dissipation approaches  $P_{\text{RMS}} = V_{\text{RMS}}^2 / R_{\text{ESR}}$ .

Similarly to ESR, the capacitor's leads add equivalent series inductance or ESL to the component. This is usually significant only at relatively high frequencies. As inductive reactance is positive and increases with frequency, above a certain frequency capacitance will be canceled by inductance. High frequency engineering involves accounting for the inductance of all connections and components.

If the conductors are separated by a material with a small conductivity rather than a perfect dielectric, then a small leakage current flows directly between them. The capacitor therefore has a finite parallel resistance,[6] and slowly discharges over time (time may vary greatly depending on the capacitor material and quality).

## Ripple current

Ripple current is the AC component of an applied source (often a [switched-mode power supply](#)) whose frequency may be constant or varying. Certain types of capacitors, such as electrolytic [tantalum](#) capacitors, usually have a rating for maximum ripple current (both in frequency and magnitude). This ripple current can cause damaging heat to be generated within the capacitor due to the current flow across resistive imperfections in the materials used within the capacitor, more commonly referred to as [equivalent series resistance](#) (ESR). For example electrolytic tantalum capacitors are limited by ripple current and generally have the highest ESR ratings in the capacitor family, while ceramic capacitors generally have no ripple current limitation and have some of the lowest ESR ratings.

## Instability of capacitance

The capacitance of certain capacitors decreases as the component ages. In ceramic capacitors, this is caused by degradation of the dielectric. The type of dielectric and the ambient operating and storage temperatures are the most significant aging factors, while the operating voltage has a smaller effect. The aging process may be reversed by heating the component above the [Curie point](#). Aging is fastest near the beginning of life of the component, and the device stabilizes over time.<sup>[15]</sup> Electrolytic capacitors age as the [electrolyte evaporates](#). In contrast with ceramic capacitors, this occurs towards the end of life of the component.

Temperature dependence of capacitance is usually expressed in parts per million (ppm) per °C. It can usually be taken as a broadly linear function but can be noticeably non-linear at the temperature extremes. The temperature coefficient can be either positive or negative, sometimes even amongst different samples of the same type. In other words, the spread in the range of temperature coefficients can encompass zero. See the data sheet in the leakage current section above for an example.

Capacitors, especially older components, can absorb sound waves resulting in a [microphonic](#) effect. Vibration moves the plates, causing the capacitance to vary, in turn inducing AC current. Some dielectrics also generate [piezoelectricity](#). The resulting interference is especially problematic in audio applications, potentially causing feedback or unintended recording. In the reverse microphonic effect, the varying electric field between the capacitor plates exerts a physical force, moving them as a speaker. This can generate audible sound, but drains energy and stresses the dielectric and the electrolyte, if any.

# Capacitor types

Main article: [Types of capacitor](#)

Practical capacitors are available commercially in many different forms. The type of internal dielectric, the structure of the plates and the device packaging all strongly affect the characteristics of the capacitor, and its applications.

## Dielectric materials



Capacitor materials. From left: multilayer ceramic, ceramic disc, multilayer polyester film, tubular ceramic, polystyrene, metalized polyester film, aluminum electrolytic. Major scale divisions are in centimetres.

Most types of capacitor include a dielectric spacer, which increases their capacitance. These dielectrics are most often insulators. However, low capacitance devices are available with a [vacuum](#) between their plates, which allows extremely high voltage operation and low losses. Variable capacitors with their plates open to the atmosphere were commonly used in radio tuning circuits. Later designs use polymer foil dielectric between the moving and stationary plates, with no significant air space between them.

Several solid dielectrics are available, including [paper](#), [plastic](#), [glass](#), [mica](#) and [ceramic](#) materials. Paper was used extensively in older devices and offers relatively high voltage performance. However, it is susceptible to water absorption, and has been largely replaced by plastic film capacitors. Plastics offer better stability and aging performance, which makes them useful in timer circuits, although they may be limited to low operating temperatures and frequencies. Ceramic capacitors are generally small, cheap and useful for high frequency applications, although their capacitance varies strongly with voltage, and they age poorly. They are broadly categorized as [class 1 dielectrics](#), which have predictable variation of capacitance with temperature or [class 2 dielectrics](#), which can operate at higher voltage. Glass and mica capacitors are extremely reliable, stable and tolerant to high temperatures and voltages, but are too expensive for most mainstream applications. [Electrolytic capacitors](#) and [supercapacitors](#) are used to store small and larger amounts of energy, respectively, [ceramic capacitors](#) are often used in [resonators](#), and [parasitic capacitance](#) occurs in circuits wherever the simple conductor-insulator-conductor sequence is formed unintentionally.

Electrolytic capacitors use an aluminum or tantalum plate with an oxide dielectric layer. The second electrode is a liquid [electrolyte](#), connected to the circuit by another foil plate. Electrolytic capacitors offer very high capacitance but suffer from poor tolerances, high instability, gradual loss of capacitance especially when subjected to heat, and high leakage current. The conductivity of the electrolyte drops at low temperatures, which increases [equivalent series resistance](#). While widely used for power-supply conditioning, poor high-frequency characteristics make them unsuitable for many applications. Tantalum capacitors offer better frequency and temperature

characteristics than aluminum, but higher dielectric absorption and leakage.[16] OS-CON (or OC-CON) capacitors are a polymerized organic semiconductor solid-electrolyte type that offer longer life at higher cost than standard electrolytic capacitors.

Several other types of capacitor are available for specialist applications. supercapacitors store large amounts of energy. Supercapacitors made from carbon aerogel, carbon nanotubes, or highly porous electrode materials offer extremely high capacitance (as much as 2,500 farads) and can be used in some applications instead of rechargeable batteries. Alternating current capacitors are specifically designed to work on line (mains) voltage AC power circuits. They are commonly used in electric motor circuits and are often designed to handle large currents, so they tend to be physically large. They are usually ruggedly packaged, often in metal cases that can be easily grounded/earthed. They also are designed with direct current breakdown voltages of at least five times the maximum AC voltage.

### Structure



Capacitor packages: SMD ceramic at top left; SMD tantalum at bottom left; through-hole tantalum at top right; through-hole electrolytic at bottom right. Major scale divisions are cm.

The arrangement of plates and dielectric has many variations depending on the desired ratings of the capacitor. For small values of capacitance (microfarads and less), ceramic disks use metallic coatings, with wire leads bonded to the coating. Larger values can be made by multiple stacks of plates and disks. Larger value capacitors usually use a metal foil or metal film layer deposited on the surface of a dielectric film to make the plates, and a dielectric film of impregnated paper or plastic – these are rolled up to save space. To reduce the series resistance and inductance for long plates, the plates and dielectric are staggered so that connection is made at the common edge of the rolled-up plates, not at the ends of the foil or metalized film strips that comprise the plates.

The assembly is encased to prevent moisture entering the dielectric – early radio equipment used a cardboard tube sealed with wax. Modern paper or film dielectric capacitors are dipped in a hard thermoplastic. Large capacitors for high-voltage use may have the roll form compressed to fit into a rectangular metal case, with bolted terminals and bushings for connections. The dielectric in larger capacitors is often impregnated with a liquid to improve its properties.

Capacitors may have their connecting leads arranged in many configurations, for example axially or radially. "Axial" means that the leads are on a common axis, typically the axis of the capacitor's cylindrical body – the leads extend from opposite ends. Radial leads might more accurately be referred to as tandem; they are rarely

actually aligned along radii of the body's circle, so the term is inexact, although universal. The leads (until bent!) are usually in planes parallel to that of the flat body of the capacitor, and extend in the same direction; they are often parallel as manufactured.

Small, cheap discoidal ceramic capacitors have existed since the 1930s, and remain in widespread use. Since the 1980s, [surface mount](#) packages for capacitors have been widely used. These packages are extremely small and lack connecting leads, allowing them to be soldered directly onto the surface of [printed circuit boards](#). Surface mount components avoid undesirable high-frequency effects due to the leads and simplify automated assembly, although manual handling is made difficult due to their small size.

Mechanically controlled variable capacitors allow the plate spacing to be adjusted, for example by rotating or sliding a set of movable plates into alignment with a set of stationary plates. Low cost variable capacitors squeeze together alternating layers of aluminum and plastic with a [screw](#). Electrical control of capacitance is achievable with [varactors](#) (or varicaps), which are [reverse-biased semiconductor diodes](#) whose [depletion region](#) width varies with applied voltage. They are used in [phase-locked loops](#), amongst other applications.

## Applications

Main article: [Applications of capacitors](#)

Capacitors have many uses in electronic and electrical systems. They are so ubiquitous that it is a rare electrical product that does not include at least one for some purpose.







### System Energy Storage

A capacitor can store electric energy when disconnected from its charging circuit, so it can be used like a temporary [battery](#). Capacitors are commonly used in electronic devices to maintain power supply while batteries are being changed. (This prevents loss of information in volatile memory.)

In [car audio](#) systems, large capacitors store energy for the [amplifier](#) to use on demand.

[UPSes](#) can be equipped with [maintenance-free](#) capacitors to extend [service life](#).<sup>[17]</sup>

## Capacitor symbols

Capacitor	Polarized capacitors	Variable capacitor
		
		
		
		
		

### Pulsed power and weapons

Groups of large, specially constructed, low-inductance high-voltage capacitors (*capacitor banks*) are used to supply huge pulses of current for many pulsed power applications. These include electromagnetic forming, Marx generators, pulsed lasers (especially TEA lasers), pulse forming networks, radar, fusion research, and particle accelerators.

Large capacitor banks (reservoir) are used as energy sources for the exploding-bridgewire detonators or slapper detonators in nuclear weapons and other specialty weapons. Experimental work is under way using banks of capacitors as power sources for electromagnetic armour and electromagnetic railguns and coilguns.

### Power conditioning

Reservoir capacitors are used in power supplies where they smooth the output of a full or half wave rectifier. They can also be used in charge pump circuits as the energy storage element in the generation of higher voltages than the input voltage.

Capacitors are connected in parallel with the power circuits of most electronic devices and larger systems (such as factories) to shunt away and conceal current fluctuations from the primary power source to provide a "clean" power supply for signal or control circuits. Audio equipment, for example, uses several capacitors in this way, to shunt away power line hum before it gets into the signal circuitry. The capacitors act as a local reserve for the DC power source, and bypass AC currents from the power supply. This is used in car audio applications, when a stiffening capacitor compensates for the inductance and resistance of the leads to the lead-acid car battery.

### Power factor correction

In electric power distribution, capacitors are used for power factor correction. Such capacitors often come as three capacitors connected as a three phase load. Usually, the values of these capacitors are given not in farads but rather as a reactive power in volt-amperes reactive (VAr). The purpose is to counteract inductive loading from devices like electric motors and transmission lines to make the load appear to be

mostly resistive. Individual motor or lamp loads may have capacitors for power factor correction, or larger sets of capacitors (usually with automatic switching devices) may be installed at a load center within a building or in a large utility [substation](#).

## Supression and coupling

### Signal coupling

Main article: [capacitive coupling](#)

Because capacitors pass AC but block DC [signals](#) (when charged up to the applied dc voltage), they are often used to separate the AC and DC components of a signal. This method is known as *AC coupling* or "capacitive coupling". Here, a large value of capacitance, whose value need not be accurately controlled, but whose [reactance](#) is small at the signal frequency, is employed.

### Decoupling

Main article: [decoupling capacitor](#)

A decoupling capacitor is a capacitor used to decouple one part of a circuit from another. Noise caused by other circuit elements is shunted through the capacitor, reducing the effect they have on the rest of the circuit. It is most commonly used between the power supply and ground. An alternative name is *bypass capacitor* as it is used to bypass the power supply or other high impedance component of a circuit.

### Noise filters and snubbers

When an inductive circuit is opened, the current through the inductance collapses quickly, creating a large voltage across the open circuit of the switch or relay. If the inductance is large enough, the energy will generate a spark, causing the contact points to oxidize, deteriorate, or sometimes weld together, or destroying a solid-state switch. A [snubber](#) capacitor across the newly opened circuit creates a path for this impulse to bypass the contact points, thereby preserving their life; these were commonly found in [contact breaker ignition systems](#), for instance. Similarly, in smaller scale circuits, the spark may not be enough to damage the switch but will still [radiate](#) undesirable [radio frequency interference](#) (RFI), which a **filter** capacitor absorbs. Snubber capacitors are usually employed with a low-value resistor in series, to dissipate energy and minimize RFI. Such resistor-capacitor combinations are available in a single package.

Capacitors are also used in parallel to interrupt units of a high-voltage [circuit breaker](#) in order to equally distribute the voltage between these units. In this case they are called grading capacitors.

In schematic diagrams, a capacitor used primarily for DC charge storage is often drawn vertically in circuit diagrams with the lower, more negative, plate drawn as an arc. The straight plate indicates the positive terminal of the device, if it is polarized

(see [electrolytic capacitor](#)).

## Motor starters

Main article: [motor capacitor](#)

In single phase [squirrel cage](#) motors, the primary winding within the motor housing isn't capable of starting a rotational motion on the rotor, but is capable of sustaining one. To start the motor, a secondary winding is used in series with a non-polarized [starting capacitor](#) to introduce a lag in the sinusoidal current through the starting winding. When the secondary winding is placed at an angle with respect to the primary winding, a rotating electric field is created. The force of the rotational field is not constant, but is sufficient to start the rotor spinning. When the rotor comes close to operating speed, a centrifugal switch (or current-sensitive relay in series with the main winding) disconnects the capacitor. The start capacitor is typically mounted to the side of the motor housing. These are called capacitor-start motors, and have relatively high starting torque. There are also capacitor-run induction motors which have a permanently-connected phase-shifting capacitor in series with a second winding. The motor is much like a two-phase induction motor.

Motor-starting capacitors are typically non-polarized electrolytic types, while running capacitors are conventional paper or plastic film dielectric types.

## Signal processing

The energy stored in a capacitor can be used to represent [information](#), either in binary form, as in [DRAMs](#), or in analogue form, as in [analog sampled filters](#) and [CCDs](#). Capacitors can be used in [analog circuits](#) as components of integrators or more complex filters and in [negative feedback](#) loop stabilization. Signal processing circuits also use capacitors to [integrate](#) a current signal.

## Tuned circuits

Capacitors and [inductors](#) are applied together in [tuned circuits](#) to select information in particular frequency bands. For example, [radio receivers](#) rely on variable capacitors to tune the station frequency. Speakers use passive analog [crossovers](#), and analog equalizers use capacitors to select different audio bands.

The [resonant frequency](#)  $f$  of a tuned circuit is a function of the inductance (L) and capacitance (C) in series, and is given by:

$$f = \frac{1}{2\pi\sqrt{LC}}$$

where L is in [henries](#) and C is in [farads](#).

## Sensing

Most capacitors are designed to maintain a fixed physical structure. However, various factors can change the structure of the capacitor; the resulting change in capacitance can be used to sense those factors.

Changing the dielectric:

The effects of varying the physical and/or electrical characteristics of the **dielectric** can also be of use. Capacitors with an exposed and porous dielectric can be used to measure humidity in air. Capacitors are used to accurately measure the fuel level in airplanes; as the fuel covers more of a pair of plates, the circuit capacitance increases.

Changing the distance between the plates:

Capacitors with a flexible plate can be used to measure strain or pressure. Industrial pressure transmitters used for process control use pressure-sensing diaphragms, which form a capacitor plate of an oscillator circuit. Capacitors are used as the sensor in condenser microphones, where one plate is moved by air pressure, relative to the fixed position of the other plate. Some accelerometers use MEMS capacitors etched on a chip to measure the magnitude and direction of the acceleration vector. They are used to detect changes in acceleration, eg. as tilt sensors or to detect free fall, as sensors triggering airbag deployment, and in many other applications. Some fingerprint sensors use capacitors. Additionally, a user can adjust the pitch of a theremin musical instrument by moving his hand since this changes the effective capacitance between the user's hand and the antenna.

Changing the effective area of the plates:

Capacitive touch switches are now used on many consumer electronic products.

## Hazards and safety



Lichtenberg figures are produced by inducing a capacitor failure in a capacitor with a solid dielectric.

Capacitors may retain a charge long after power is removed from a circuit; this charge can cause shocks or damage to connected equipment. For example, even a seemingly innocuous device such as a disposable camera flash unit powered by a 1.5 volt AA battery contains a capacitor which may be charged to over 300 volts. This is easily

capable of delivering a shock. Service procedures for electronic devices usually include instructions to discharge large or high-voltage capacitors. Capacitors may also have built-in discharge resistors to dissipate stored energy to a safe level within a few seconds after power is removed. High-voltage capacitors are stored with the terminals shorted, as protection from potentially dangerous voltages due to dielectric absorption.

Some old, large oil-filled capacitors contain polychlorinated biphenyls (PCBs). It is known that waste PCBs can leak into groundwater under landfills. Capacitors containing PCB were labelled as containing "Askarel" and several other trade names. PCB-filled capacitors are found in very old (pre 1975) fluorescent lamp ballasts, and other applications.

High-voltage capacitors may catastrophically fail when subjected to voltages or currents beyond their rating, or as they reach their normal end of life. Dielectric or metal interconnection failures may create arcing that vaporizes dielectric fluid, resulting in case bulging, rupture, or even an explosion. Capacitors used in RF or sustained high-current applications can overheat, especially in the center of the capacitor rolls. Capacitors used within high-energy capacitor banks can violently explode when a short in one capacitor causes sudden dumping of energy stored in the rest of the bank into the failing unit. High voltage vacuum capacitors can generate soft X-rays even during normal operation. Proper containment, fusing, and preventive maintenance can help to minimize these hazards.

High-voltage capacitors can benefit from a pre-charge to limit in-rush currents at power-up of HVDC circuits. This will extend the life of the component and may mitigate high-voltage hazards.

## Notes

1. ^ Henry Smith Williams. "A History of Science Volume II, Part VI: The Leyden Jar Discovered".  
<http://www.worldwideschool.org/library/books/sci/history/AHistoryofScienceVolumell/chap49.html>.
2. ^ Houston, Edwin J. (1905). *Electricity in Every-day Life*. P. F. Collier & Son.  
[http://books.google.com/books?id=ko9BAAAAIAAJ&pg=PA71&dq=jar+%22von+Kleist%22&lr=&as\\_brr=1&ei=aniTR\\_uCJ5HwsgOQ5bU4#PPA71,M1](http://books.google.com/books?id=ko9BAAAAIAAJ&pg=PA71&dq=jar+%22von+Kleist%22&lr=&as_brr=1&ei=aniTR_uCJ5HwsgOQ5bU4#PPA71,M1).
3. ^ Dorf, p.257
4. ^ **a b** Ulaby, p.168
5. ^ Ulaby, p.157
6. ^ **a b** Ulaby, p.169
7. ^ Hammond, P, *Electromagnetism for Engineers*, pp44-45, Pergamon Press, 1965.
8. ^ Dorf, p.263
9. ^ Dorf, p.260
10. ^ "Capacitor charging and discharging : DC CIRCUITS". *All About Circuits*. [http://www.allaboutcircuits.com/vol\\_6/chpt\\_3/17.html](http://www.allaboutcircuits.com/vol_6/chpt_3/17.html). Retrieved on 2009-02-19.
11. ^ Ulaby, p.170
12. ^ S. T. Pai and Qi Zhang (1995). *Introduction to High Power Pulse Technology*. World Scientific. ISBN 9810217145. <http://books.google.com/books?>

[id=spZ\\_H4nwlN0C&pg=PA47&dq=breakdown+field+energy-density+dielectric&ei=bUGySNuEB4XWsgPf\\_4W8BA&sig=ACfU3U2ooCfDPKtlcl-yPee-vr\\_jMt6W3A.](#)

13. <sup>^</sup> Scherz, P, *Practical Electronics for Inventors*, p100, McGraw-Hill Professional, 2006, [ISBN 0071452818](#).
14. <sup>^</sup> Bird, J, *Electrical Circuit Theory and Technology*, p501, Newnes, 2007, [ISBN 075068139X](#).
15. <sup>^</sup> [Ceramic Capacitor Aging Made Simple](#)
16. <sup>^</sup> [Ask The Applications Engineer - 21](#) , Steve Guinta, Analog Devices
17. <sup>^</sup> [http://www.industrial-europe.com/showArticle.jhtml?articleID=210602105&cid=NL\\_industrialeu](http://www.industrial-europe.com/showArticle.jhtml?articleID=210602105&cid=NL_industrialeu)

## References

- Dorf, Richard C.; Svoboda, James A. (2001). *Introduction to Electric Circuits* (5th ed.). New York: John Wiley and Sons, Inc.. [ISBN 0-471-38689-8](#).
- Ulaby, Fawwaz T. (1999). *Fundamentals of Applied Electromagnetics* (1999 ed.). Upper Saddle River, New Jersey: Prentice-Hall. [ISBN 0-13-011554-1](#).
- Zorpette, Glenn (2005). "[Super Charged: A Tiny South Korean Company is Out to Make Capacitors Powerful enough to Propel the Next Generation of Hybrid-Electric Cars](#)". *IEEE Spectrum* **42** (1): 32. doi:10.1109/MSPEC.2005.1377872. ISSN 0018-9235. <http://www.spectrum.ieee.org/jan05/2777>.
- *The ARRL Handbook for Radio Amateurs* (68th ed.). Newington CT USA: The Amateur Radio Relay League. 1991.
- Huelsman, Lawrence P. (1972). *Basic Circuit Theory with Digital Computations*. Series in computer applications in electrical engineering. Englewood Cliffs: Prentice-Hall. [ISBN 0-13-057430-9](#).
- Philosophical Transactions of the Royal Society LXXII, Appendix 8, 1782 (Volta coins the word *condenser*)
- A. K. Maini "Electronic Projects for Beginners", "Pustak Mahal", 2nd Edition: March, 1998 ([INDIA](#))
- [Spark Museum](#) (von Kleist and Musschenbroek)
- [Biography of von Kleist](#)

## External links

- [Capacitance and Inductance](#) - a chapter from an online textbook
- [Howstuffworks.com: How Capacitors Work](#)
- [CapSite 2008: Introduction to Capacitors](#)
- [AC circuits](#)
- [Capacitor Tutorial](#) - Includes how to read capacitor temperature codes
- [Capacitors in Circuits](#) by Ernest Lee, [The Wolfram Demonstrations Project](#).
- [Instructables: DIY Make a Toy Capacitor](#)
- [Capacitor Converters and Calculators](#)
- [Summary of the different types of capacitors](#) with additional pages giving more in-depth information on the individual capacitor types